

Model T-1 Yacht Horn

Kahlenberg Chimetone Air Horns all utilize more than one projector or “trumpet” in their design. These projectors each produce a different fundamental frequency which combine to produce powerful, distinctive, musical chords. To hear a Chimetone Air Horn is to realize that the sound of a vessel can be one of its most impressive aspects. The Model T-1 Air Horn is designed for the most discriminating yachtsman. It is made entirely of bronze and brass, and available in triple chrome plate or a variety of other finishes.



- **FOR VESSELS LESS THAN 75 METERS IN LENGTH**
- **MEETS OR EXCEEDS IMO REQUIREMENTS**
- **LOW AIR CONSUMPTION, OPERATES ON A WIDE RANGE OF AIR PRESSURE**
- **HIGHLY RELIABLE, VIRTUALLY NO MAINTENANCE**
- **OPTIONAL DIRECTLY MANIFOLDED MANUAL/SOLENOID VALVES, AIR STRAINER AND MANEUVERING LIGHT**

TECHNICAL DATA

Fundamental Frequency: 375, 322, and 252 Hz

S.P.L. : (1/3 Octave @ 1 Meter): 132 dB

Air Consumption:

35 C.F.M. @ 100 p.s.i., 17 l/s @ 7 bar

Air Pressure Required:

100 to 250 p.s.i., 7 to 17 bar
(Higher pressures with optional regulators)

Electrical Power Required:

Any standard A.C. or D.C. Voltage

Material: Cast Bronze and Spun Brass

Net Weight: 23 lbs., 10 kg.

Finish:

Kahlenberg Chrome Plate, TGIC Sky White Powdercoat, Gold or Black Chrome PVD

Dimensions:

18.5" x 13.75" x 13" (470x349x330)

Conforming to International Maritime Regulations
For Vessels Less Than 75 Meters in Length.

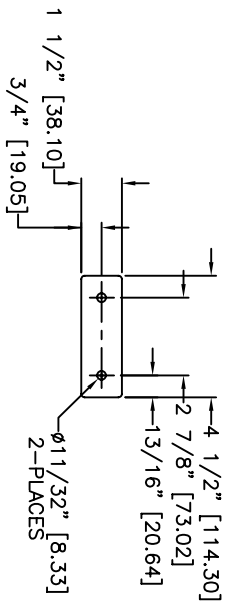
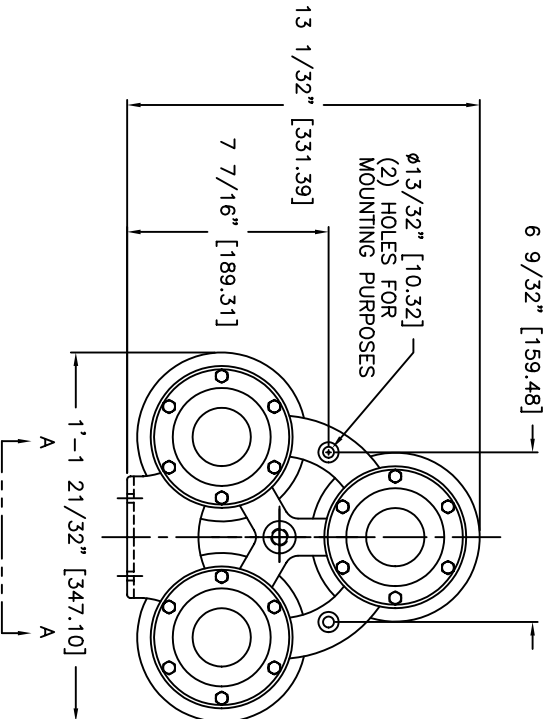
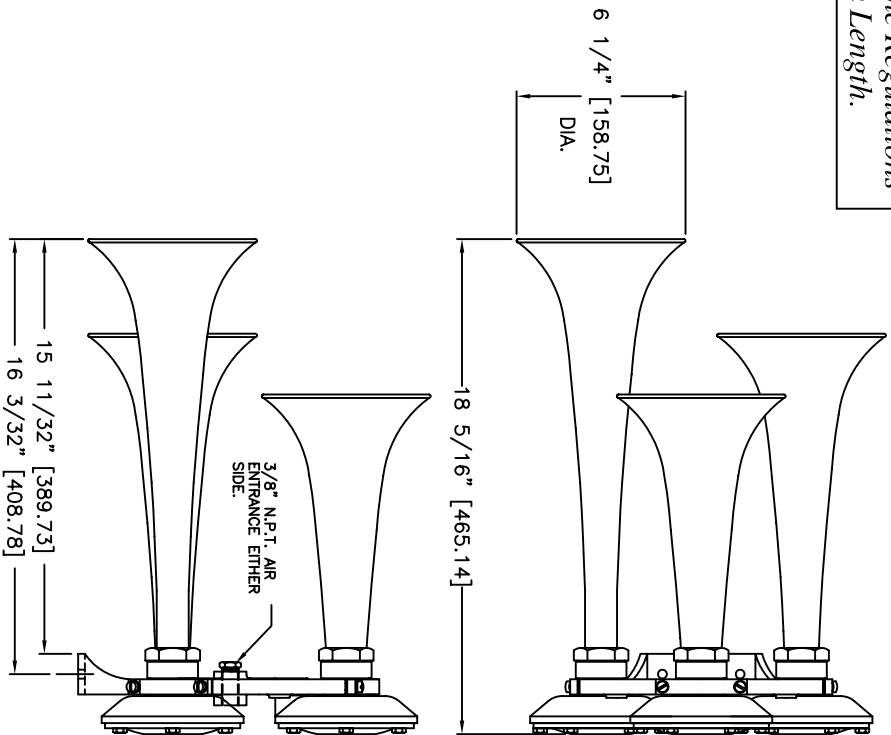

VIEW "A"- "A"

TECHNICAL DATA

Frequency: 375 Hz, 322 Hz, 252 Hz
 Sound Pressure Level (dB(A) at 1 meter): 139dB
 Sound Pressure Level (1/3 octave at 1 meter): 132dB
 Air Consumption: appx. 51.6 C.F.M. @ 150 P.S.I.
 Air Pressure Req: 100 To 250 P.S.I.
 Electric Power: N/A
 Material: Spun Brass & Cast Bronze
 Net Weight: 23 Lbs.
 Shipping Weight: 63 Lbs.

Price: \$ _____ U.S.D. Net. Ea.
 (Valid for 60 days, F.O.B. Two Rivers, WI, U.S.A.)



KAHLENBERG BROS. CO. TWO RIVERS, WI, U.S.A.

OUTLINE DIMENSIONS
MODEL T-1, FIG. 311
AIRHORN

DATE	DRWG. NO.	REV.
04/12/01	3-4205	A EMK